

## infinite pulleys

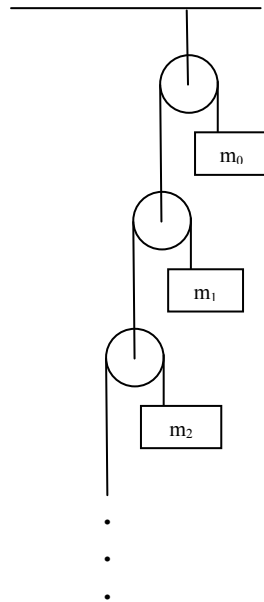

An infinite series of pulleys and masses is arranged as shown, with  $m_0 = 1/(1-t)$ , and  $m_i = t^{(i-1)}$  for  $i > 0$ , with  $0 < t < 1$ . At the moment the pulleys are released from rest, what is the acceleration of mass  $m_0$ ?

### Solution by Sukumar Chandra:

In case of an infinite pulley system, any of the pulleys can be replaced by an equivalent finite mass without changing the motion of the masses above it. Let us consider the  $i^{\text{th}}$  pulley (starting from  $0^{\text{th}}$ ). On its one side is suspended the mass  $m_i$  and other side the pulley  $(i+1)^{\text{th}}$ . Let us replace the  $(i+1)^{\text{th}}$  pulley by a finite mass  $M_i$  without changing the motion of the system above it.

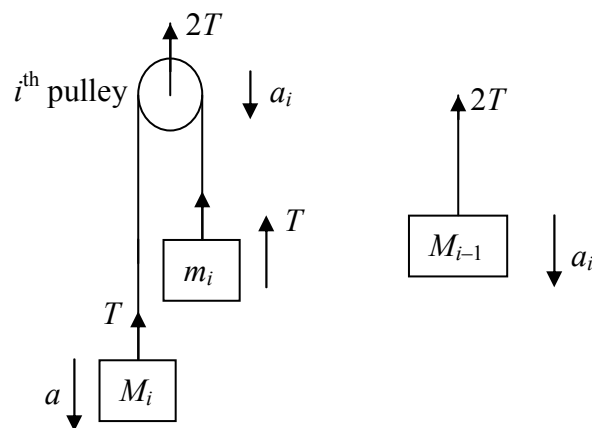

Let the  $i^{\text{th}}$  pulley move down with acceleration  $a_i$  while, with respect to this pulley, mass  $m_i$  moves up with acceleration  $a$  and mass  $M_i$  moves down with acceleration  $a$ . If tension in the string joining the two masses be  $T$  then tension on the pulley is  $2T$ . We can replace the  $i^{\text{th}}$  pulley by a mass  $M_{i-1}$  moving down with same acceleration  $a_i$  as the pulley and experiencing same tension  $2T$ .

Equation of motion of  $m_i$  is:

$$T - m_i g = m_i (a - a_i)$$

Equation of motion of  $M_i$  is:

$$M_i g - T = m_i (a + a_i)$$

Eliminating  $a$  from these two equations we get,

$$T = \frac{2m_i M_i}{m_i + M_i} (g - a_i) \quad (1)$$

Also, Equation of motion of  $M_{i-1}$  is  $M_{i-1} g - 2T = M_{i-1} a_i$ , or

$$2T = M_{i-1} (g - a_i) \quad (2)$$

Comparing equations (1) & (2) we can declare  $M_{i-1} = \frac{4m_i M_i}{m_i + M_i}$ , which is independent of  $a_i$ !

Putting  $m_i = t^{i-1}$  (as given), we get

$$M_{i-1} = \frac{4M_i t^{i-1}}{M_i + t^{i-1}} = \frac{4}{\frac{1}{M_i} + \frac{1}{t^{i-1}}} = \frac{4}{\frac{1}{M_i} + \frac{t}{t^i}}$$

Hence on two sides of the pulley number  $(i-1)$  we have now the masses  $M_{i-1}$  and  $m_{i-1}$  without disturbing the motion of the masses and pulleys above it. In a similar manner the pulley number  $(i-1)$  can be replaced by a mass  $M_{i-2}$  such that

$$M_{i-2} = \frac{4M_{i-1} m_{i-1}}{M_{i-1} + m_{i-1}} = \frac{4}{\frac{1}{M_{i-1}} + \frac{1}{t^{i-2}}} = \frac{4}{\frac{1}{\frac{4}{\frac{1}{M_i} + \frac{t}{t^i}} + \frac{t^2}{t^i}}} = \frac{4^2}{\frac{1}{M_i} + \frac{t}{t^i} + 4\frac{t^2}{t^i}} = \frac{4^2}{\frac{1}{M_i} + \frac{t}{t^i} (1 + 4t)}$$

Similarly the pulley  $(i-2)$  can be replaced by a mass  $M_{i-3}$ , which comes to, in similar simplification,

$$M_{i-3} = \frac{4^3}{\frac{1}{M_i} + \frac{t}{t^i} (1 + 4t + (4t)^2)}$$

Thus we get a definite series for the masses of the successive higher pulleys with which they can be replaced without affecting the accelerations of the masses above them.

Proceeding in this way, the pulley number 1, which is connected to the top most mass  $m_0$ , can be replaced by a mass  $M_0$  which can be written as

$$M_0 = \frac{4^i}{\frac{1}{M_i} + \frac{t}{t^i} (1 + 4t + (4t)^2 + (4t)^3 + \dots + (4t)^{i-1})}$$

Or (using the summation rule for G.P. series),

$$M_0 = \frac{4^i}{\frac{1}{M_i} + \frac{t}{t^i} \left( \frac{1 - (4t)^i}{1 - 4t} \right)}$$

$$= \frac{1}{\frac{1}{4^i M_i} + \frac{t}{1 - 4t} \left( \frac{1}{(4t)^i} - 1 \right)}$$

As  $i \rightarrow \infty$ ,  $\frac{1}{4^i M_i}$  vanishes, but  $\frac{1}{(4t)^i}$  will vanish only if  $4t > 1$  (i.e.  $t > 1/4$ ), and in that case  $M_0$  exists and becomes equal to  $\frac{4t-1}{t}$ . On the other hand if  $4t \leq 1$  (i.e.  $t \leq 1/4$ ) then  $M_0 \rightarrow \infty$ . Also,  $a$ , the downward acceleration of  $m_0$ , can be expressed as

$$a = \frac{(m_0 - M_0)g}{m_0 + M_0} = \frac{\left( \frac{m_0}{M_0} - 1 \right)g}{\frac{m_0}{M_0} + 1} \tag{3}$$

Hence we get, when  $t \leq 1/4$ ,  $M_0 \rightarrow \infty$ , and  $a = -g$ . On the other hand, when  $t > 1/4$ ,  $M_0 = \frac{4t-1}{t}$ ; substituting this into equation (3) and using  $m_0 = \frac{1}{1-t}$  (as given) we get, after simplification,

$$a = \frac{g}{1 - \frac{2t}{(2t-1)^2}}$$

but when  $2t = 1$  (i.e.  $t = 1/2$ ),  $a$  is undefined. In fact, when  $t = 1/2$ ,  $M_0 = m_0 = 2$  and hence from equation (3),  $a = 0$ .

*Thus, for  $t \geq 1/4$ ,  $a = -g$ , for  $t = 1/2$ ,  $a = 0$ , and for other values of  $t$ ,  $a = g / (1 - 2t / (2t - 1)^2)$ .*